



# SMART GAS MIXER

SGM100

---

## SMART GAS MIXER (SGM100)



## DIMENSIONS

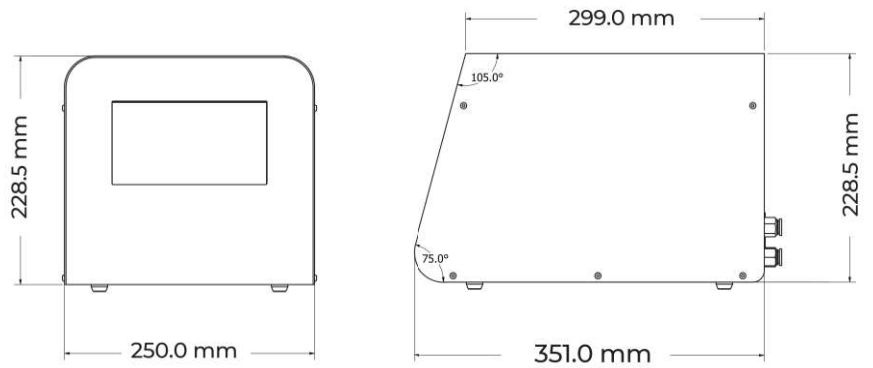

## KEY FEATURES

- Provides precise mixing for desired gas ratio for food packaging lines using Modified Atmosphere Packaging (MAP).
- Record and tracks gas mixing history.
- User-friendly interface with easy operation and data security password-protection.
- Support wireless network capability.

## TECHNICAL SPECIFICATIONS

Dimensions (L x W x H)	351.0 mm x 250.0 mm x 228.5 mm
Weight	12.0 kg
Voltage	220 - 240 VAC, 50 Hz
Power Consumption	110 W
Gasses	Oxygen (O <sub>2</sub> ), Nitrogen (N <sub>2</sub> ), Carbon Dioxide (CO <sub>2</sub> )
Number of Input Gases	2 gases or 3 gases
Gas Inlet Pressure	2 - 10 Bar
Gas Outlet Pressure	0 - 9 Bar
Flow Capacity	Up to 138L/min
Flow Measuring	Total and daily consumption of gasses used
Alarm	Inlet and outlet pressure alarm
Mixer Accuracy	± 2% absolute in flow ranges above 20 l/min total output flow

## INTERFACE

User Interface	7-Inch touch screen
Connectivity	RS485, USB, LAN

## GAS CONNECTION

Gas Inlet	Gas pipe $\Phi$ 10mm, 1/4" BSW
Gas Outlet	Gas pipe $\Phi$ 10mm, 1/4" BSW

## ACCESSORIES

Pressure Accumulator	20 liters Max. pressure 10 bar
----------------------	-----------------------------------